

Ersatzteilliste
Spare parts list
Liste de pièces de rechange
Lista de piezas de recambio

Motorsägen 639 / 645 / 639 DEKO
Chain saws
Tronçonneuses
Motosierras

MADE IN GERMANY
MADE BY SOLO



Zeichenerklärung

Legend

Légende

Leyenda

ØXXXXX Bis Serien-Nr.
 XXXXXØ Ab Serien-Nr.
 + Neues Teil gegenüber D 9 639 701
 *+ Neues Teil gegenüber D 9 639 701,
 mit Bezug auf Serien-Nr.

up to serial no.
 as of serial no.
 new part compared to D 9 639 701
 new part compared to D 9 639 701,
 referring to serial no.

jusqu'au no. de série
 à partir de no. de série
 nouvelle pièce par rapport à D 9 639 701
 nouvelle pièce par rapport à D 9 639 701,
 se référant au no. de série

hasta no. de serie
 desde de no. de serie
 parte nuevo comparado con D 9 639 701
 parte nuevo comparado con D 9 639 701
 referente al no. de serie

D 9 639 702

solo[®]



Bild-Nr. Pos.-No. Pos.-No. Pos.-No.	Bestell-Nr. Order-No. No. de Cde. Ref.-Nr.	Modell Type Modele Modelo	Menge Quantity Nombres Cantidad	Motor	Engine	Moteur	Motor
1	00 20 145		1	Sechskantmutter M8x1 DIN ISO 8673	nut	écrou	tuerca
2	00 72 145		1	Spannscheibe 8,0 DIN 6796	disc spring	rondelle de tension	arandela elastica
5	24 00 285		1	Lüfterrad	fan wheel	volant magnétique	turbina
7	20 74 294		1	Lagerhülse 35x45,13x17,2	bearing sleeve	bague côté allumage	casquillo
8	00 54 220		1	Wellendichtring 15x28x5	oil seal	joint spy	reten
9	00 50 102		1	Kugellager 15x35x11	ball bearing	roulement à billes	cojinete
10	22 00 942		1	Kurbelwelle, kompl., enth.(crankshaft, kompl.incl.(vilebrequin, compl., incl.(cigüenal, compl., incl.(
(7)	20 74 294		1	Lagerhülse 35x45,13x17,2	bearing sleeve	bague côté allumage	casquillo
(8)	00 54 220		1	Wellendichtring 15x28x5	oil seal	joint spy	reten
(9)	00 50 102		1	Kugellager 15x35x11	ball bearing	roulement à billes	cojinete
(12)	22 00 235		1	Kurbelwelle	crankshaft	embellage	cigüenal
(15)	00 50 188		1	Kugellager 15x35x13	ball bearing	roulement à billes	cojinete de bolas
(16)	00 54 265		1	Wellendichtring 15x29,6x4	oil seal	joint spy	reten
(17)	20 74 293		1	Lagerhülse 34,9x45,2x19	sleeve	bague côté transmission	casquillo
(20)	00 55 136		1	Sicherungsring 15x1 DIN 471 A	circlip	circlip	presilla
11	00 52 226		1	Nadelkäfig 9x13x12,5	needle bearing	roulement à aiguilles	casquillo de cojinete
12	22 00 235		1	Kurbelwelle	crankshaft	embellage	cigüenal
15	00 50 188		1	Kugellager 15x35x13	ball bearing	roulement à billes	cojinete de bolas
16	00 54 265		1	Wellendichtring 15x29,6x4	oil seal	joint spy	reten
17	20 74 293		1	Lagerhülse 34,9x45,2x19	sleeve	bague côté transmission	casquillo
20	00 55 136		1	Sicherungsring 15x1 DIN 471 A	circlip	circlip	presilla
21	00 31 270		1	Scheibe 15x22x0,5 DIN 988	washer	rondelle	arandela
22	60 74 976		1	Mitnehmerschnecke mit Feder	activator	entraîneur	activador
25	60 42 817		1	Scheibe 12,5x19x0,5	washer	rondelle	arandela
26	35 00 405		1	Fliehkraftkupplung	centrifugal clutch	embrayage centrifuge	embrague centrifugo
27	00 71 226		2	Druckfeder 1,7x6,2x17,5	pressure spring	ressort d'embrayage	resorte
28	35 00 362P		1	Kupplungsglocke .325"	clutch drum	cloche embrayage	campana
29	00 52 257		1	Nadelkäfig 10x13x13	needle bearing	roulement à aiguilles	cojinete
30	62 00 131		1	Bremssband, kompl.	brake band, compl.	sangle frein de chaîne, compl.	cinta de freno, compl.
31	00 70 254		1	Druckfeder 1,6x10,2x56	pressure spring	ressort de pression	resorte
32	63 00 208		1	Verstellung	linkage	poussoir ressort frein	varilla
35	60 43 990		1	Schutzkappe	protection cap	capuchon de protection	caperuza de protecc.
36	00 55 104		1	Sicherungsscheibe 8 DIN 6799	circlip	rondelle	seguro
40	60 74 999		1	Bremssbandabdeckung	brake band cover	couvercle de frein de chaîne	chapa cintra de freno
41	00 18 354		3	Linsenschraube 4x12	screw	vis	tornillo
44	60 31 993		2	Distanzbuchse 8,5x18,6/14,5x5,8	sleeve	entretoise	casquillo
45	61 00 371		1	Schwertabdeckung, rot	chain guard, red	carter de chaîne, rouge	chapa espada, rojo
46	00 20 214		2	Sechskantmutter M8 DINISO 4032	nut	écrou	tuerca
48	00 69 788		1	Selbstklebeschild "SOLO"	decal	autocollant	etiqueta
50	61 00 369		1	Hauptgehäuse, rot	main casing, red	carter principal, rouge	carter principal, rojo
51	00 28 150		1	Blechmutter 3,5	nut	écrou	tuerca
52	00 62 288		1	O-Ring 25,2x3	o-ring	joint torique	anillo
53	27 00 345		1	Tankverschluss, Öl, enth.:(oil tank cap, incl.(bouchon réservoir huile, incl.(tapa de deposito, incl.(
(52)	00 62 288		1	O-Ring 25,2x3)	o-ring)	joint torique)	(anillo)
55	00 73 397		2	Dämpfungsfeder 2,5x13,5x55	av spring	ressort amortisseur	resorte
56	00 18 361		4	Linsenschraube 5x12	screw	vis	tornillo
60	00 18 340		4	Zylinderschraube M5x40	screw	vis	tornillo
61	00 72 140		4	Tellerfeder 5,2x12x0,5 DIN 2093 A	disc spring	rondelle	arandela
62	00 33 358		4	Distanzrohr 8/7,6x1,2x27,5	spacer tube	entre toise	tubo distanciadior
65	60 74 997		1	Hubstift 3x21	pin	goujon	perno
66	00 62 256		1	O-Ring 4x1,2	o-ring	joint torique	anillo
67	00 46 145		1	Bolzen 2x5x31	bolt	axe de retenue	perno
70	00 84 477		1	Kurzschluß-Schalter	short circuit button	bouton marche arret	interruptor
72	00 69 841		1	Selbstklebeschild "STOP"	sticker "STOP"	autocollant "STOP"	placa "STOP"
75	60 74 992		1	Stift, Halbgas	pin, half throttle	levier mi-gaz	perno
76	60 74 993		1	Chokehebel	choke lever	levier starter	palanca choke
77	00 84 634		1	Kurzschlußkabel	short-circuit cable	câble court-circuit	cable cortocircuito
79	67 00 124		1	Ölsieb	oil strainer	crépine d'huile	filtro
80	60 63 329		1	Ölschlauch 3,5x88	oil hose	durite d'huile	tubo de aceite
81	60 63 323		1	Dichtstück	seal	caoutchouc d'étanchéité	junta
82	00 18 354		2	Linsenschraube 4x12	screw	vis	tornillo
83	00 62 276		1	O-Ring 4,7x1	o-ring	joint torique	anillo
84	00 31 529		2	Anlaufscheibe 8x5,1x0,5	friction washer	rondelle	arandela
85	00 70 265		1	Druckfeder 0,5x5,7x27	pressure spring	ressort de pression	resorte de presion
86	60 31 996		1	Pumpenkolben	pump piston	piston de la pompe	piston de la bomba
90	64 00 222		1	Ölpumpe, kompl., enth.:(oil pump, compl., incl.(pompe à huile, compl., incl.(bomba de aceite, compl., incl.(
(83)	00 62 276		1	O-Ring 4,7x1	o-ring	joint torique	anillo
(84)	00 31 529		2	Anlaufscheibe 8x5,1x0,5	friction washer	rondelle	arandela
(85)	00 70 265		1	Druckfeder 0,5x5,7x27	pressure spring	ressort de pression	resorte de presion
(86)	60 31 996		1	Pumpenkolben)	pump piston)	piston de la pompe)	piston de la bomba)
92	00 73 381		1	Drehfeder 1,3x7,1	torsion spring	ressort	resorte
94	27 00 339		1	Rückschlagventil	check valve	soupape antiretour	valvula

Bild-Nr. Pos.-No. Pos.-No. Pos.-No.	Bestell-Nr. Order-No. No. de Cde. Ref.-Nr.	Modell Type Modèle Modelo	Menge Quantity Nombres Cantidad	Motor	Engine	Moteur	Motor
94	27 00 382 *++		1	Rückschlagventil	check valve	soupape antiretour	valvula
96	00 18 380		2	Stiftschraube M8x19	screw	vis	tornillo
97	60 43 979		1	Kettenschutzblech	chain protection plate	protection chaîne	chapa protecc. cadena
98	00 18 354		1	Linsenschraube 4x12	screw	vis	tornillo
100	63 00 175		1	Druckblech	pressure plate	levier de blocage	soporte
101	00 40 188		1	Zylinderstift 5 H8x14	pin	axe	pasador
102	00 70 253		1	Druckfeder 1,5x7x21,5	pressure spring	ressort de pression	resorte
105	00 28 149		1	Blechmutter 4,8	nut	écrou	tuerca
106	00 73 397		1	Dämpfungsfeder 2,5x13,5x33	av spring	ressort	resorte
107	00 18 257		1	Linsenschraube 5x25	screw	vis	tornillo
108	00 18 361		1	Linsenschraube 5x12	screw	vis	tornillo
110	60 32 640		1	Kettenspannbolzen	chain tension bolt	tendeur de chaîne	perno de fijación de cad.
111	00 18 230		1	Spannschraube M5x48	tension screw	vis tendeur de chaîne	tornillo
119	20 48 358	639	2	Kolbenring 39x1,5	piston ring	ségment	anillo de piston
119	20 48 229	645	2	Kolbenring 42x1,5	piston ring	ségment	anillo de piston
120	22 00 240	639	1	Kolben Ø 39, enth.:(piston, incl.(piston, incl.(piston, incl.(
(119)	20 48 358	639	2	Kolbenring 39x1,5)	piston ring)	ségment)	anillo de piston)
120	22 00 242	645	1	Kolben Ø 42, enth.:(piston, incl.(piston, incl.(piston, incl.(
(119)	20 48 229	645	2	Kolbenring 42x1,5)	piston ring)	ségment)	anillo de piston)
122	20 31 117P		1	Kolbenbolzen 9/6x28	piston pin	axe de piston	bulon
123	00 55 278		2	Sprengring 9x0,8 DIN 73160	ring	circlips d'axe de piston	anillo
125	20 63 321		1	Zylinderfußdichtung	gasket	joint d'embase cylindre	junta
130	20 11 755	639	1	Nikasilzylinder Ø 39	cylinder	cylindre	cilindro
130	20 11 754	645	1	Nikasilzylinder Ø 42	cylinder	cylindre	cilindro
130	20 11 813	639 DEKO	1	Nikasilzylinder Ø 39 für Dekovent.	cylinder	cylindre	cilindro
131	28 00 570	639 DEKO	1	Dekoventil D 1,0	deco-valve	deco-soupape	deco-valvula
133	00 67 125		1	Impulsanschluß	impulse connection	raccord d'impulsion	conexion
134	00 64 319		1	Schlauch 5x1,5	hose	tuyau	tubo
135	00 15 282		1	Stiftschraube M5x11	screw	goujon	tornillo
137	23 00 730		1	Zündkerze WSR 6 F 200	spark plug	bougie	bujia
140	60 63 322		1	Verbindungsschlauch	hose connection	raccord d'admission	tubo
141	00 71 153		2	Ringfeder	spring ring	bague ressort	resorte
144	23 00 708		1	Vergaserstutzen	manifold	bride d'admission	munon de carburador
144	60 74 994 *+		1	Vergaserstutzen	manifold	bride d'admission	munon de carburador
145	00 18 274		2	Linsenschraube 5x16	screw	vis	tornillo
146	20 61 477		1	Vergaserstutzendichtung	manifold gasket	joint bride carburateur	junta
150	23 00 704		1	Vergaser HDA 126	carburetor	carburateur	carburador
150	23 00 709 *+		1	Vergaser HDA 127	carburetor	carburateur	carburador
151	20 74 983		1	Düsenführung	nozzle guide	guidage vis carburateur	guia tobera
152	28 00 329		1	Gasgestänge	throttle linkage	tringle	varilla de gas
153	60 74 916		1	Rasthebel	stop lever	levier à cran	palanca de engaste
157	25 00 679		1	Filtergehäuse Oberteil	filter housing	filtre à air (partie sup.)	caja de filtro
158	00 73 391		2	Klemmprofil 3x20	profile	profil	perfil
158	20 74 946 *+++		2	Klemmprofil 4x2x20	profile	profil	perfil
160	25 00 664		1	Luftfilter, kompl., enth.:(air filter, compl., incl.(filtre à air, compl., incl.(filtro de aire, compl., incl.(
(157)	25 00 679		1	Filtergehäuse Oberteil	filter housing	filtre à air (partie sup.)	caja de filtro
(158)	00 73 391		2	Klemmprofil 3x20	profile	profil	perfil
(158)	20 74 946 *+++		2	Klemmprofil 4x2x20	profile	profil	perfil
162	00 18 363		2	Linsenschraube 5x20	screw	vis	tornillo
163	00 30 108		1	Scheibe 5,3 DIN 125 B	washer	rondelle	arandela
165	00 34 201		2	Schnorricherung 5	circlip	rondelle crantée	anillo circlip
166	00 18 382		2	Linsenschraube 5x55	screw	vis	tornillo
170	60 63 301		1	Schlauchdurchführung	hose guide	mousse de protection	guia tubo
171	00 64 300		1	Schlauch 3x1,5	tube	tuyau	tubo
172	00 64 407		1	Schlauch 2x1,5	tube	tuyau	tubo
173	27 00 322		1	Primer	primer	pompe d'amorcage	cabador
175	00 18 379		3	Vierkantschraube M5x72,2	screw	vis	tornillo
176	20 61 476		1	Auspuffdichtung 1,0 dick	exhaust gasket	joint d'echappement	junta de escape
177	25 00 665		1	Auspuff	exhaust	echappement	escape
178	00 72 144		3	Spannscheibe 5,0 DIN 6796 A	washer	rondelle de tension	disco
179	00 28 137		3	Sechskantmutter M5 DIN 980	lock nut	écrou	tuerca
182	20 48 360	USA	1	Funkenschutz	spark arrestor	protec. étincelle	protec. de la chispa
183	00 10 370	USA	1	Zylinderschraube 4,2x9,5 DIN 7971	screw	vis	tornillo
185	00 73 385		1	Kontaktfeder	contact spring	ressort de contact	resorte de contacte
186	00 84 600		1	Zündkerzenstecker	spark plug cap	capuchon de bougie	tapa bujia
190	23 00 703		1	Zündmodul PHELON, enth.:(ignition module, incl.(bobine d'allumage, incl.(bobina, incl.(
(185)	00 73 385		1	Kontaktfeder	contact spring	ressort de contact	resorte de contacte
(186)	00 84 600		1	Zündkerzenstecker	spark plug cap)	capuchon de bougie)	tapa bujia)
192	00 18 327		2	Zylinderschraube M4x20	screw	vis	tornillo
193	00 72 148		2	Spannscheibe 4,0 DIN 6796	disc spring	rondelle de tension	arandela elastica
194	00 30 101		1	Scheibe 4,3 DIN 433	washer	rondelle	arandela
195	00 10 128		1	Zylinderschraube M3x4 DIN 84	screw	vis	tornillo

Bild-Nr. Pos.-No. Pos.-No. Pos.-No.	Bestell-Nr. Order-No. No. de Cde. Ref.-Nr.	Modell Type Modèle Modelo	Menge Quantity Nombres Cantidad	Motor	Engine	Moteur	Motor
197 200	00 66 455 69 00 342		1	Kabelband 98x2,5 Führungsschiene, 33 cm, (13"), .325", T=1,5	cableband guide bar, 33 cm, (13"), .325", G=1,5	serre câble guide, 33 cm, (13"), .325", P=1,5	cinta de cable espada, 33 cm, (13"), .325", P=1,5
200	69 00 343			Führungsschiene, 38 cm, (15"), .325", T=1,5	guide bar, 38 cm, (15"), .325", G=1,5	guide, 38 cm, (15"), .325", P=1,5	espada, 38 cm, (15"), .325", P=1,5
200	69 00 861			Führungsschiene, 46 cm, (18"), .325", T=1,5	guide bar, 46 cm, (18"), .325", G=1,5	guide, 46 cm, (18"), .325", P=1,5	espada, 46 cm, (18"), .325", P=1,5
201 205 206 207 208 209 210	60 71 258 05 40 239 05 40 260 05 40 253 05 40 238 05 40 279 69 00 7045		1	Kettenschutz 44 cmx11 Verbindungsglied mit Niet Treibglied Linksschneider Verbindungsglied ohne Niet Rechtsschneider	chain guard connection link with rivet drive link left cutter connection link without rivet right cutter	fourreau de chaîne maillon d'attache avec rivet maillon entraineur gouge gauche maillon d'attache sans rivet gouge droite	proteccion cadena eslabón de conexión con remache eslabón cortador izquierda eslabón de conexión sin remache cortador derecha
210	69 00 8755			Vollmeißelkette, 33 cm, (13"), .325", T=1,5, 56 Treibglieder	chain, 33 cm, (13"), .325", G=1,5	chaîne, 33 cm, (13"), .325", P=1,5	cadena, 33 cm, (13"), .325", P=1,5
210	69 00 8755			Vollmeißelkette, 38 cm, (15"), .325", T=1,5, 64 Treibglieder	chain, 38 cm, (15"), .325", G=1,5	chaîne, 38 cm, (15"), .325", P=1,5	cadena, 38 cm, (15"), .325", P=1,5
210	69 00 8845			Vollmeißelkette, 46 cm, (18"), .325", T=1,5, 72 Treibglieder	chain, 46 cm, (18"), .325", G=1,5	chaîne, 46 cm, (18"), .325", P=1,5	cadena, 46 cm, (18"), .325", P=1,5
215	00 80 494		1	Schraubendreher 3 "SOLO"	screw-driver	tournevis	destornillador
216	00 80 489		1	Kombischlüssel 19	combi wrench	clef universelle	llave
217	60 43 323		1	Anschlagkralle	bucking spike	griffe	garra de apoyo
218	00 18 362		2	Zylinderschraube	screw	vis	tornillo
220	05 10 888		1	Dichtungssatz - Vergaser HDA 126	gasket-kit - carburetor	pochette - carburateur	juego de juntas-carburador
220	05 10 952 *+		1	Dichtsatz - Vergaser HDA 127	gasket-kit - carburetor	pochette de joints - carburateur	juego de juntas - carburador
221	05 10 887		1	Reparatursatz - Vergaser HDA 126	repair-kit - carburetor	pochette - carburateur	juego de rep. - carburador
221	05 10 951 *+		1	Reparatursatz - Vergaser HDA 127	repair-kit - carburetor	kit de réparation - carburateur	juego de rep. - carburador
222	05 10 953		1	Drosselachsen-kit - Vergaser HDA 127	throttle axle kit - carburetor	kit axe clapet gaz - carburateur	juego de mariposa - carburador
223	05 10 954		1	Chokeachsen-kit - Vergaser HDA 127	choke axle kit - carburetor	kit axe clapet starter - carburateur	juego eje choke - carburador

*+ : 639: 1135Ø
645: 2501Ø

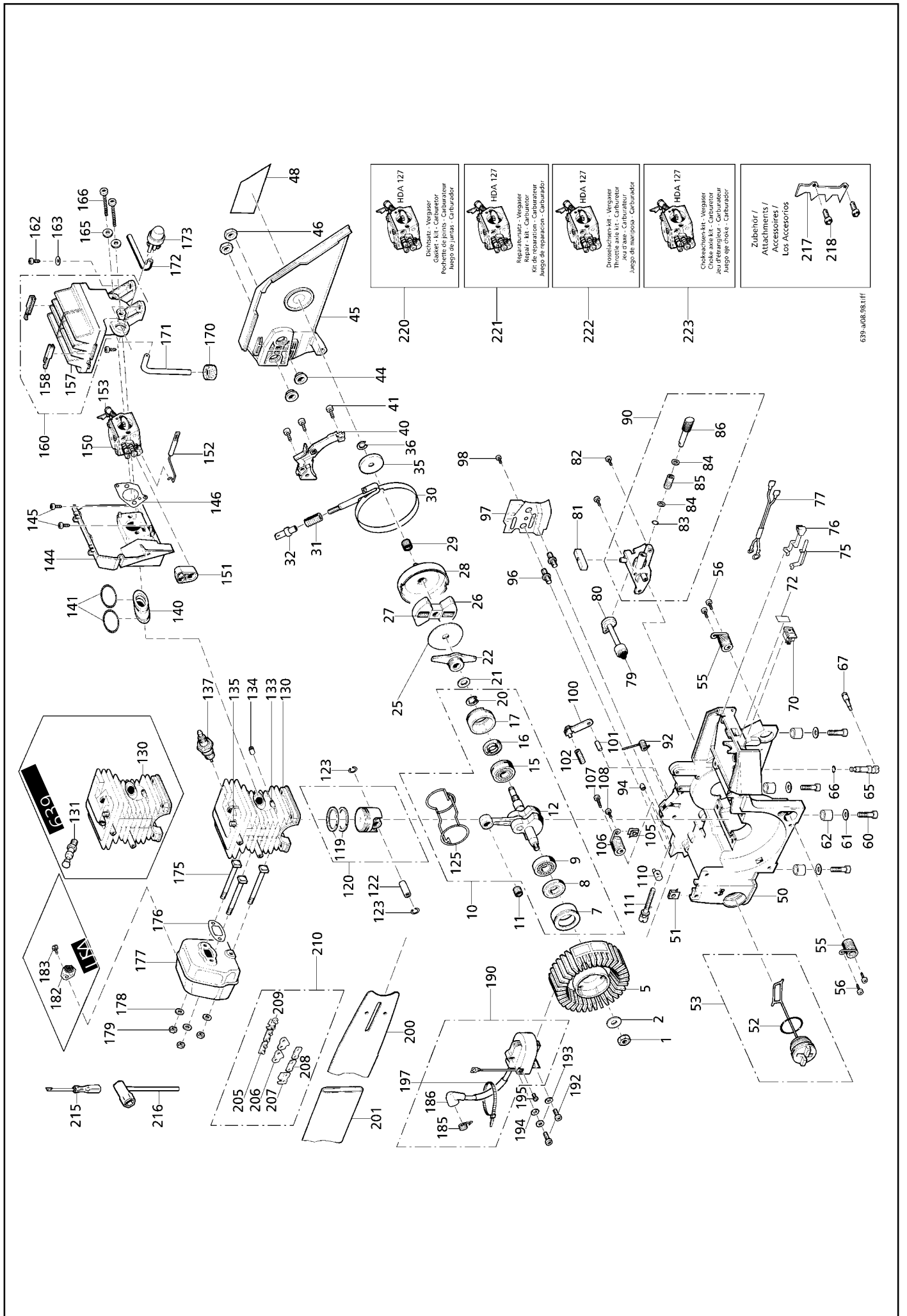
*++ : 639: 35006Ø
645: 26437Ø

*+++ : 639: 39320Ø
645: 28421Ø

639 DEKO



Bild-Nr. Pos.-No. Pos.-No.	Bestell-Nr. Order-No. No. de Cde. Ref.-Nr.	Modell Type Modelo	Menge Quantity Nombres Cantidad	Bügel/Hand- griff	Handle bar	Etrier	Asa
1	61 00 368		1	Griffgehäuse, rot	handle housing, red	carter réservoir, rouge	carter, rojo
2	00 18 363		1	Linsenschraube 5x20	screw	vis	tornillo
5	00 73 392		1	Schenkelfeder 0,8x10,5	spring	ressort de gâchette	resorte
6	60 74 988		1	Lagerstift 6x21	pin	axe de gâchette	perno
7	20 74 979		1	Gashebel	throttle lever	gâchette d'accélérateur	palanca
8	20 36 381		1	Gasstange 2	throttle linkage	tringle de liaison	varilla de gas
10	60 73 615		1	Griffschale	handle cup	1/2 poignée arrière	casaca
11	60 74 989		1	Sicherungshebel	safety lever	levier de sécurité	palanca
12	60 74 292		1	Blockierhebel	lock lever	levier de bloquage	palanca
13	00 73 398		1	Drehfeder 0,7x7,7	spring	ressort	resorte
15	60 63 301		2	Schlauchdurchführung	hose guide	mousse de protection	guia tubo
16	00 64 300		1	Schlauch 3x1,5	tube	tuyau	tubo
17	30 48 280		1	Sinterfilter	sinter filter	filtre d'aération	filtro
19	00 13 214		1	Linsenblechschraube 3,5x19 DIN 7981	screw	vis	tornillo
20	25 00 640		1	Entlüftungsschlauch 3x1,5x130, enth.:(vent hose, incl.(tuyau d'aération, incl.(tubo de ventilacion, incl.(
(16)	00 64 300		1	Schlauch 3x1,5	tube	tuyau	tubo
(17)	30 48 280		1	Sinterfilter	sinter filter)	filtre d'aération)	filtro)
25	60 63 301		1	Schlauchdurchführung	hose guide	mousse de protection	guia tubo
26	00 73 351		1	Schlauchöse 6,7x0,9x2	hose fitting	collier	manguito de cable
27	60 63 326		1	Kraftstoffschlauch 3x119	fuel hose	durite essence	tubo gasolina
29	27 00 327		1	Benzinsucher	fuel pick-up	crépine à essence	filtro de gasolina
35	00 98 121		1	Fangsicherung	safety catch	bandelette de retenue	fijacion
36	00 72 144		1	Scheibe 5 DIN 6796 B	washer	rondelle	arandela
37	00 18 361		1	Linsenschraube 5x12	screw	vis	tornillo
40	60 74 991		1	Haltebügel	handle bar	étrier de maintien	estribo
43	00 30 108		1	Scheibe 5,3 DIN 125 B	washer	rondelle	arandela
44	00 18 363		1	Linsenschraube 5x20	screw	vis	tornillo
45	00 94 294		1	Anschlagpuffer	buffer	butée	tope
48	00 18 275		2	Linsenschraube 5x30	screw	vis	tornillo
49	00 73 397		1	Dämpfungsfeder 2,5x13,5x23	av spring	ressort amortisseur	resorte
50	00 18 275		1	Linsenschraube 5x30	screw	vis	tornillo
51	00 18 361		1	Linsenschraube 5x12	screw	vis	tornillo
55	60 73 638		1	Handschutz	hand protection	protège main	proteccion de mano
57	00 18 355		1	Linsenschraube 4x16	screw	vis	tornillo
58	00 44 280		1	Rohrniet 6x0,75x4 DIN 7340 A	rivet	rivet	remache
60	00 72 140		1	Tellerfeder 5,2x12x0,5 DIN 2093 A	disc spring	rondelle	resorte
61	00 42 306		1	Paßhülse 7/5,3x9,5	sleeve	bague	casquillo
62	00 30 108		1	Scheibe 5,3 DIN 125 B	washer	rondelle	arandela
63	00 18 274		1	Linsenschraube 5x16	screw	vis	tornillo
65	00 28 118		1	Sechskantmutter M4 DIN 980	nut	écrou	tuerca
66	60 32 669		1	Schaltbolzen	shift bolt	axe commande de frein	bulon
70	60 42 827		2	Isolierfolie	isolating foil	lamelle isolatrice	caminilla
71	00 69 923		1	Selbstklebeschild "Gehörschutz"	decal	autocollant	etiqueta
72	00 11 302		1	Haubenschraube M5x14	screw	vis	tornillo
75	61 00 375		1	Haube, kompl., enth.:(cover, compl., incl.(capot moteur, compl., incl.(cubierta, compl., incl.(
75	61 00 411	639 DEKO	1	Haube, kompl. für Dekoventil, enth.:(cover, compl., incl.(capot moteur, compl., incl.(cubierta, compl., incl.(
(70)	60 42 827		2	Isolierfolie	isolating foil	lamelle isolatrice	caminilla
(71)	00 69 484		1	Selbstklebeschild "Gehörschutz"	decal	autocollant	etiqueta
(72)	00 20 214		1	Sechskantmutter M8 DIN ISO 4032)	nut)	écrou)	tuercas)
77	00 69 879	639	1	Selbstklebeschild "SOLO 639"	sticker "SOLO 639"	autocollant "SOLO 639"	placa "SOLO 639"
77	00 69 880	645	1	Selbstklebeschild "SOLO 645"	sticker "SOLO 645"	autocollant "SOLO 645"	placa "SOLO 645"
80	00 62 280		1	O-Ring 30x3	ring	joint torique	anillo
81	27 00 344		1	Tankverschluß, Benzin, enth.:(tank cap, incl.(bouchon d'essence, incl.(tapa de deposito, incl.(
(80)	00 62 280		1	O-Ring 30x3)	ring)	joint torique)	anillo)



639-c/08.98.tiff

Bild-Nr. Pos.-No. Pos.-No. Pos.-No.	Bestell-Nr. Order-No. No. de Cde. Ref.-Nr.	Modell Type Modèle Modelo	Menge Quantity Nombres Cantidad	Starter	Starter	Lanceur	Arranque
1	00 69 889		1	Selbstklebeschild "SOLO"	decal "SOLO"	autocollant "STOP"	adhesivo "SOLO"
2	00 18 363		4	Linsenschraube 5x20	screw	vis	tornillo
5	60 73 617		1	Startergehäuse, rot	starter housing, red	carter de lanceur, rouge	carter de arranque, rojo
7	00 63 186		1	Starterseil 3,5x900	starter rope	corde de lanceur	cuerda de arranque
8	20 74 206		1	Startergriff	starter handle	poignée de lanceur	manija
10	26 00 283		1	Feder-cassette	spring cassette	ressort de lanceur	caja de resortes
11	20 74 419		1	Seilrolle	starter pulley	poulie de lanceur	roldana
12	20 74 209		1	Starterklinke	starter pawl	cliquet de lanceur	trinquete
13	20 74 408		1	Kulisse	template	coulisse	colisa
14	00 73 365		1	Federstecker 1,4	pin	goupille beta	chaveta
15	26 00 275		1	Starter, kompl., rot	starter, compl., red	lanceur, compl., rouge	arranque, compl., rojo

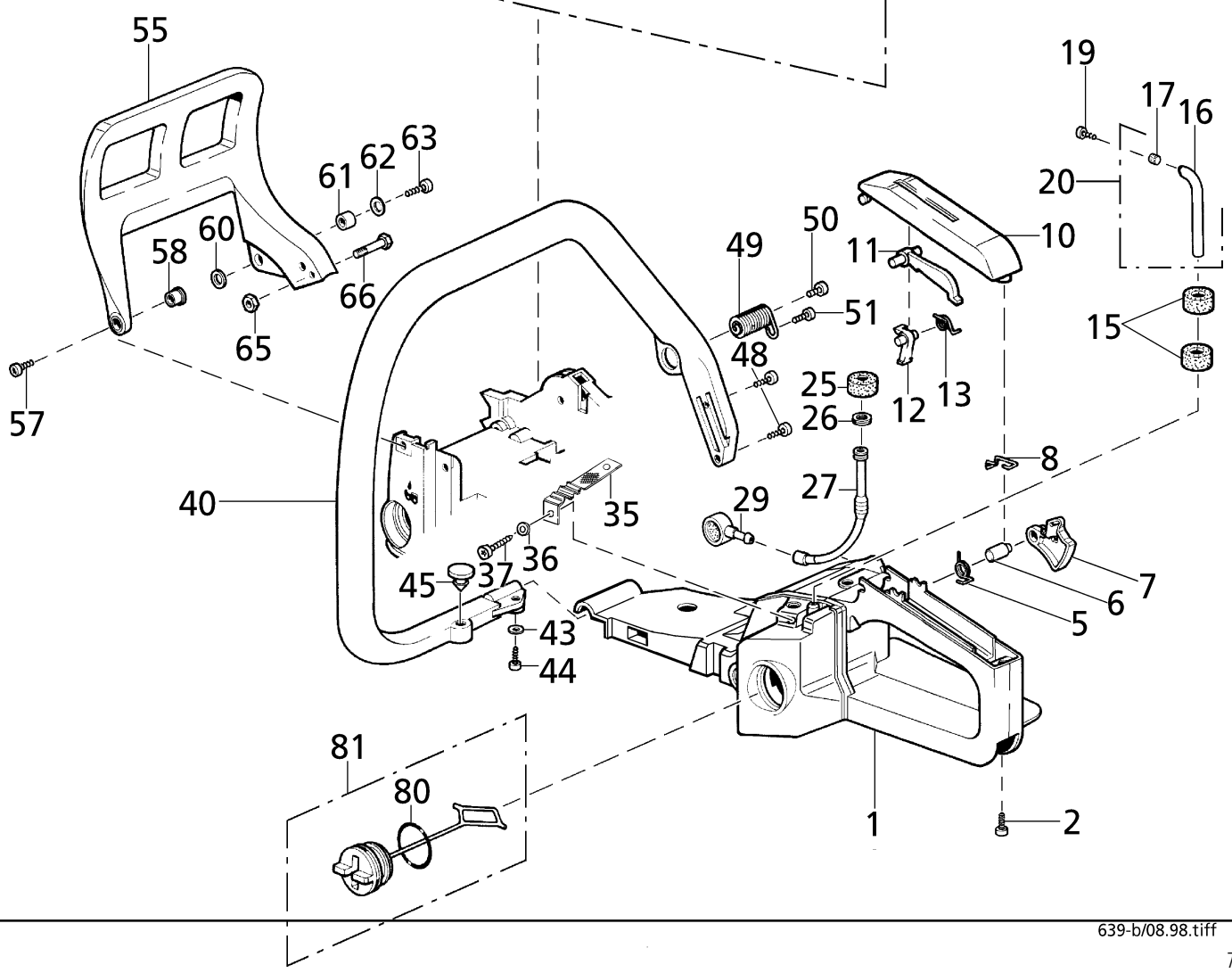
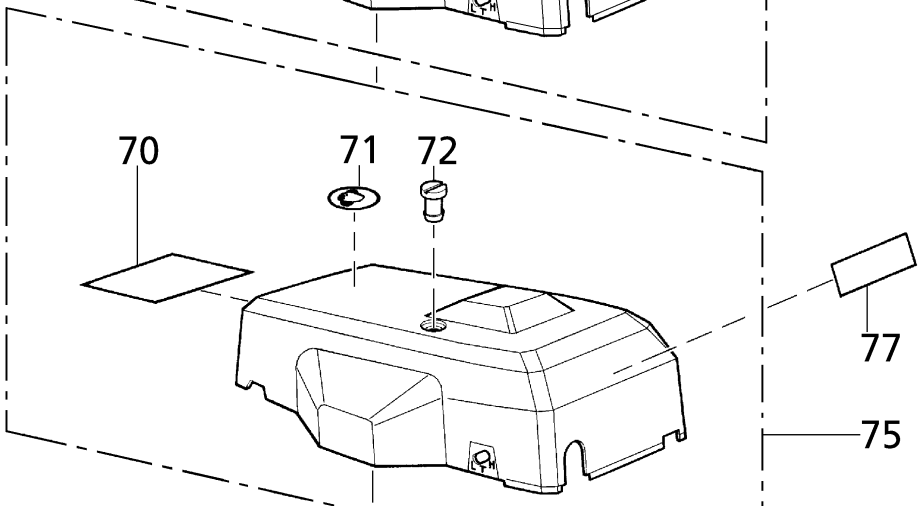
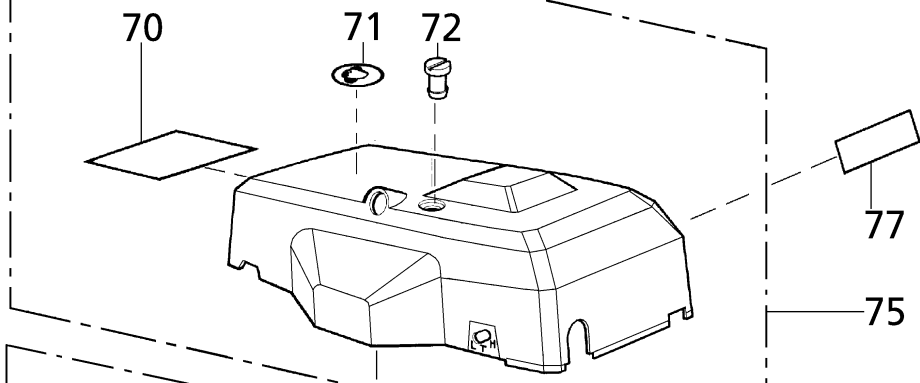
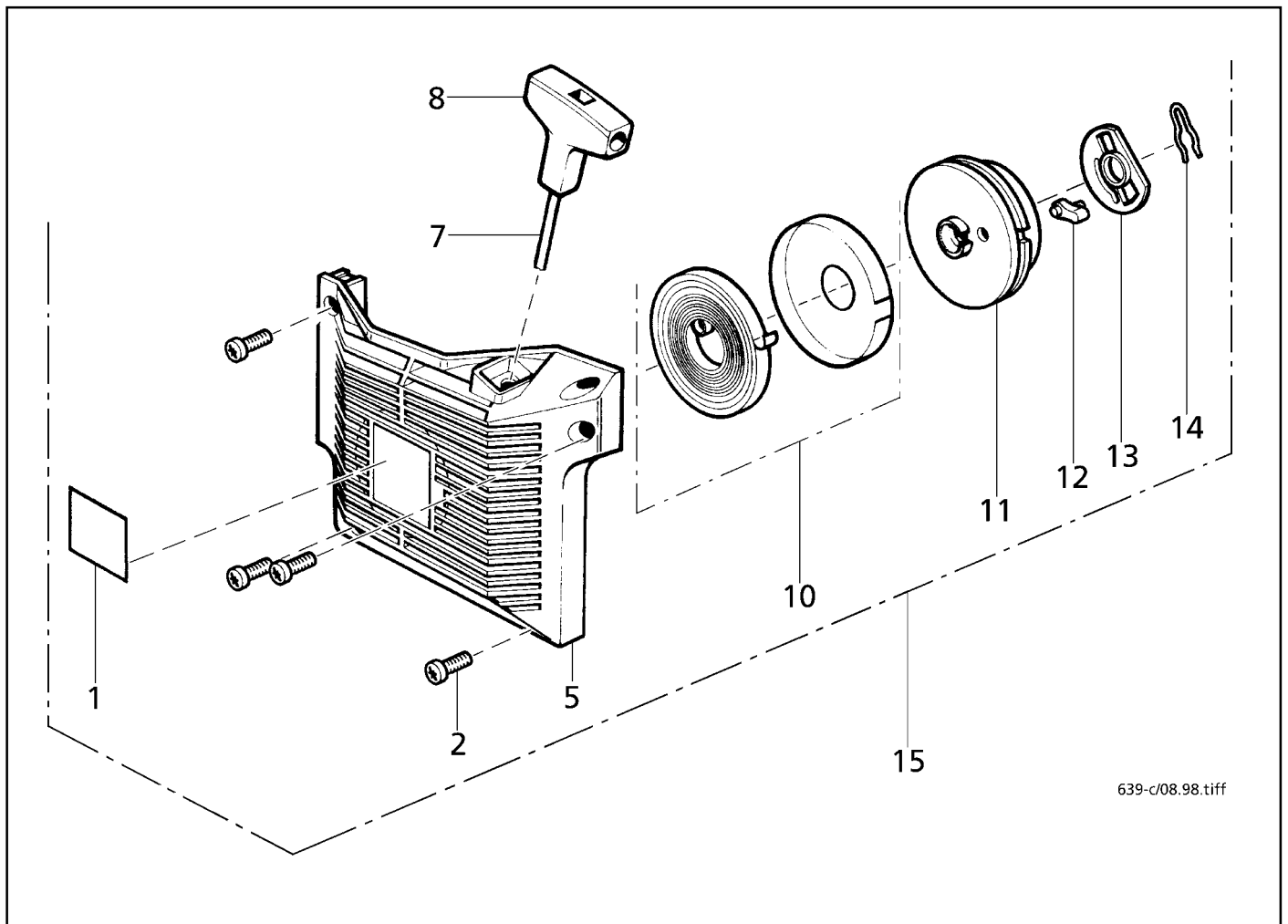
Bestell-Nr. Order-No. No. de Cde. Ref.-Nr.	Menge Quantity Nombres Cantidad	Seite page page pagina	Bestell-Nr. Order-No. No. de Cde. Ref.-Nr.	Menge Quantity Nombres Cantidad	Seite page page pagina	Bestell-Nr. Order-No. No. de Cde. Ref.-Nr.	Menge Quantity Nombres Cantidad	Seite page page pagina	Bestell-Nr. Order-No. No. de Cde. Ref.-Nr.	Menge Quantity Nombres Cantidad	Seite page page pagina
00 10 128	1	5	00 62 288	1	4	20 48 358	2	5	60 73 617	1	10
00 10 370	1	5	00 63 186	1	10	20 48 360	1	5	60 73 638	1	9
00 11 302	1	9	00 64 300	1	5	20 61 476	1	5	60 74 292	1	9
00 13 214	1	9	00 64 300	1	9	20 61 477	1	5	60 74 916	1	5
00 15 282	1	5	00 64 319	1	5	20 63 321	1	5	60 74 976	1	4
00 18 230	1	5	00 64 407	1	5	20 74 206	1	10	60 74 988	1	9
00 18 257	1	5	00 66 455	1	6	20 74 209	1	10	60 74 989	1	9
00 18 274	2	5	00 67 125	1	5	20 74 293	1	4	60 74 991	1	9
00 18 274	1	9	00 69 788	1	4	20 74 294	1	4	60 74 992	1	4
00 18 275	2	9	00 69 841	1	4	20 74 408	1	10	60 74 993	1	4
00 18 275	1	9	00 69 879	1	9	20 74 419	1	10	60 74 994	*+1	5
00 18 327	2	5	00 69 880	1	9	20 74 946	*+2+	5	60 74 997	1	4
00 18 340	4	4	00 69 889	1	10	20 74 979	1	9	60 74 999	1	4
00 18 354	3	4	00 69 923	1	9	20 74 983	1	5	61 00 368	1	9
00 18 354	2	4	00 70 253	1	5	22 00 235	1	4	61 00 369	1	4
00 18 354	1	5	00 70 254	1	4	22 00 240	1	5	61 00 371	1	4
00 18 355	1	9	00 70 265	1	4	22 00 242	1	5	61 00 375	1	9
00 18 361	4	4	00 71 153	2	5	22 00 942	1	4	61 00 411	1	9
00 18 361	1	5	00 71 226	2	4	23 00 703	1	5	62 00 131	1	4
00 18 361	1	9	00 72 140	4	4	23 00 704	1	5	63 00 175	1	5
00 18 361	1	9	00 72 140	1	9	23 00 708	1	5	63 00 208	1	4
00 18 362	2	6	00 72 144	3	5	23 00 709	*+1	5	64 00 222	1	4
00 18 363	2	5	00 72 144	1	9	23 00 730	1	5	67 00 124	1	4
00 18 363	1	9	00 72 145	1	4	24 00 285	1	4	69 00 342		6
00 18 363	1	9	00 72 148	2	5	25 00 640	1	9	69 00 343		6
00 18 363	4	10	00 73 351	1	9	25 00 664	1	5	69 00 704S		6
00 18 379	3	5	00 73 365	1	10	25 00 665	1	5	69 00 861		6
00 18 380	2	5	00 73 381	1	4	25 00 679	1	5	69 00 875S		6
00 18 382	2	5	00 73 385	1	5	26 00 275	1	10	69 00 884S		6
00 20 145	1	4	00 73 391	2	5	26 00 283	1	10			
00 20 214	2	4	00 73 392	1	9	27 00 322	1	5			
00 28 118	1	9	00 73 397	2	4	27 00 327	1	9			
00 28 137	3	5	00 73 397	1	5	27 00 339	1	4			
00 28 149	1	5	00 73 397	1	9	27 00 344	1	9			
00 28 150	1	4	00 73 398	1	9	27 00 345	1	4			
00 30 101	1	5	00 80 489	1	6	27 00 382	*+1	5			
00 30 108	1	5	00 80 494	1	6	28 00 329	1	5			
00 30 108	1	9	00 84 477	1	4	28 00 570	1	5			
00 30 108	1	9	00 84 600	1	5	30 48 280	1	9			
00 31 270	1	4	00 84 634	1	4	35 00 362P	1	4			
00 31 529	2	4	00 94 294	1	9	35 00 405	1	4			
00 33 358	4	4	00 98 121	1	9	60 31 993	2	4			
00 34 201	2	5	05 10 887	1	6	60 31 996	1	4			
00 40 188	1	5	05 10 888	1	6	60 32 640	1	5			
00 42 306	1	9	05 10 951	*+1	6	60 32 669	1	9			
00 44 280	1	9	05 10 952	*+1	6	60 42 817	1	4			
00 46 145	1	4	05 10 953	1	6	60 42 827	2	9			
00 50 102	1	4	05 10 954	1	6	60 43 323	1	6			
00 50 188	1	4	05 40 238		6	60 43 979	1	5			
00 52 226	1	4	05 40 239		6	60 43 990	1	4			
00 52 257	1	4	05 40 253		6	60 63 301	1	5			
00 54 220	1	4	05 40 260		6	60 63 301	2	9			
00 54 265	1	4	05 40 279		6	60 63 301	1	9			
00 55 104	1	4	20 11 754	1	5	60 63 322	1	5			
00 55 136	1	4	20 11 755	1	5	60 63 323	1	4			
00 55 278	2	5	20 11 813	1	5	60 63 326	1	9			
00 62 256	1	4	20 31 117P	1	5	60 63 329	1	4			
00 62 276	1	4	20 36 381	1	9	60 71 258	1	6			
00 62 280	1	9	20 48 229	2	5	60 73 615	1	9			

Bestell-Nr. Order-No. No. de Cde. Ref.-Nr.	Menge Quantity Nombres Cantidad	Seite page page pagina	Bestell-Nr. Order-No. No. de Cde. Ref.-Nr.	Menge Quantity Nombres Cantidad	Seite page page pagina	Bestell-Nr. Order-No. No. de Cde. Ref.-Nr.	Menge Quantity Nombres Cantidad	Seite page page pagina	Bestell-Nr. Order-No. No. de Cde. Ref.-Nr.	Menge Quantity Nombres Cantidad	Seite page page pagina

Allgemeine Richtlinien für die Bestellung von Original SOLO Ersatzteilen:

Voraussetzung für eine reibungslose Erledigung sind folgende Angaben:

1. Ersatzteil-Bestellnummer
2. Gewünschte Anzahl
3. Typenbezeichnung des Geräts

Diese Ersatzteilliste ist für die Lieferung und Ausstattung von SOLO Erzeugnissen unverbindlich.
Im Interesse der technischen Weiterentwicklung bleiben Konstruktionsänderungen vorbehalten.

General Directions for Ordering Original SOLO Spare Parts:

Spare parts orders are to be placed with the SOLO Sales Branch or SOLO Distributor. For correct and diligent processing of your order, please give the following information:

1. Spare Part number
2. Quantity
3. Model and serial number
4. Shipping instructions

Delivery is made in accordance with our general sales and delivery conditions. This spare parts list is non-committal for us with regard to delivery and layout of SOLO products. In favour of technical improvements, design modifications are subject to change without notice.

Directives générales pour les commandes de pièces de rechange d'origine SOLO:

Il est indispensable de préciser dans toutes les commandes de pièces:

1. - le numéro de référence de la pièce
2. - la quantité
3. - le type de la machine
4. - le mode d'expédition

Les livraisons sont effectuées dans le cadre de nos conditions générales de vente. Toutes modifications réservées.

Directivas Generales de pedido de la firma SOLO:

Por adelantado de un arreglo sin dificultades necesitamos siguientes indicaciones:

1. Número de repuesto
2. Numero de cantidad
3. Modelo y número de serial
4. Instrucción de Envío

Este lista de repuestos no es obligatoria para los envíos y/o forma de equipo de los productos SOLO.
En el interés del constante desarrollo debemos reservarnos el derecho de cambios.

SOLO Kleinmotoren
G m b H
Postfach 60 01 52
D-71050 Sindelfingen
Germany

Telefon 07031/301-0
Telefax 07031/301-130
Export 07031/301-149

<http://www.solo-germany.com>
e-mail: info@solo-germany.com

Zentral-Ersatzteilservice
Telefon 07031/301-209
Telefax 07031/301-206 11/98

